

Gas Chromatograph Mass Spectrometer

GCMS-QP2050

UFMS
ULTRA FAST MASS SPECTROMETRY





GCMS-QP™ 2050

Excellence Redefined

Movie



The business environments and needs involved in analysis work change on a continual basis.

The next-generation GCMS-QP2050 gas chromatograph mass spectrometer, with its accumulation of impressive Shimadzu technology, will lead the way forward. New value is provided by hardware boasting astounding reliability and stability, and easy-to-operate software equipped with superior automated technology.



Minimum Maintenance, Maximum Progress

Simple Operation, Confident Results

One Instrument, Infinite Possibilities

Minimum Maintenance, Maximum Progress

Revolutionary Platform Makes Maximum Progress

The conventional platform has significantly evolved to include the DuraEase ion source, designed in pursuit of high durability and ease of maintenance. Plus, an incomparable combination of stability and speed enables unmatched instrument uptime for maximum productivity and a faster return on investment.

Detector

The new model is equipped with both the latest noise suppression technology and high amplification performance, and can accurately assess even trace ions.

Quadrupole rods

By significantly improving mass separation performance and ion transmittance, the system achieves the industry's highest level of scan speed (30,000 u/sec). Further, the new quadrupole rod is equipped with a pre-rod, so it is maintenance-free.

Interface

In order to suppress the adsorption of high boiling point components, the new interface has been optimized to ensure a uniform temperature distribution.



DuraEase* ion source

DuraEase technology enables this next-generation ion source to achieve the industry's highest level of sensitivity, durability, and ease of maintenance.

* Shimadzu term referring to technology that meets internal standards for durability and easy maintenance.

Long-life filament



The highly durable new filament has an operating life about five times longer than usual.

Robust Engineering Minimizes Maintenance

Contamination-Resistant Ion Optical System

A contamination-resistant ion optical system in the GCMS-QP2050 keeps the frequency of maintenance to a minimum while also enabling highly reliable measurements to be performed for an extended period.

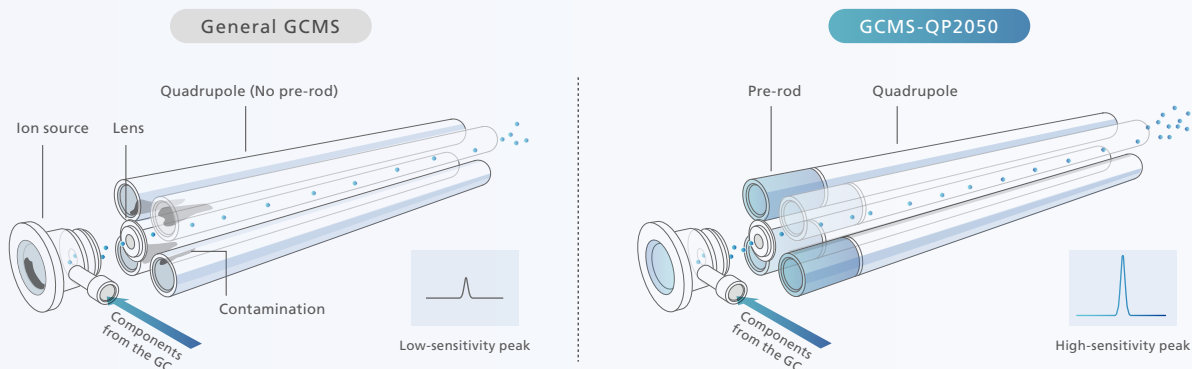

DuraEase Ion Source

The structure of the next-generation DuraEase ion source is inert and achieves a uniform temperature distribution, resulting in high sensitivity and exceptional durability.

Quadrupole Rods with Pre-Rod

The built-in pre-rod allows only the ions to efficiently pass through, limiting contamination of the quadrupole. In addition, because heating to prevent contamination is not required, it is maintenance-free.

Long-Life Filament with 1/5th the Conventional Replacement Frequency

The newly developed long-life filament has an operating life at least five times longer than conventional filaments. There are no concerns about re-analysis or downtime due to sudden filament burnout.

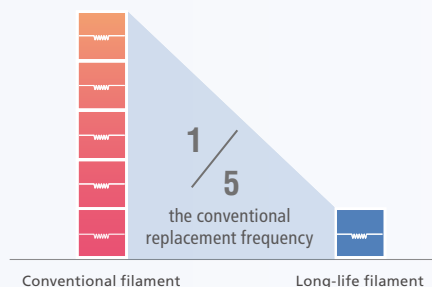

High Durability in Consecutive Analyses

Good results were obtained in the continuous analysis of 64 pesticides in food matrices (%RSD < 18.8 %). The GCMS-QP2050, boasting unparalleled robustness, provides highly stable measurements even when analyzing food samples with complex matrices.

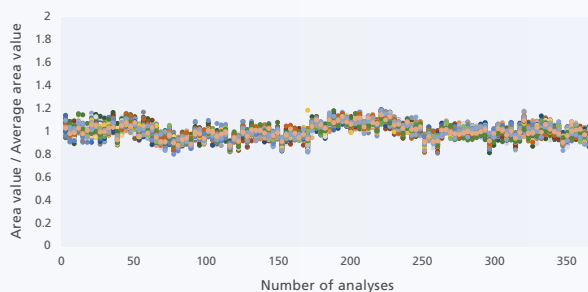

Reproducibility of peak area for 64 pesticides (10 µg/L) in food matrices (350 consecutive injections, food matrices: spinach and ginger)

*Display the area values after normalization

Simple Operation, Confident Results

Easy Maintenance

Ion Source Maintenance Takes Just One Minute

With the DuraEase ion source, the conventional ion source structure has been completely revised, in pursuit of more convenient maintenance. The ion source is disposable and no cleaning is required, so maintenance is finished in just one minute.

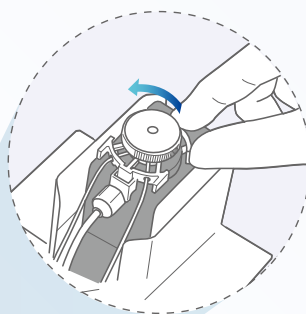
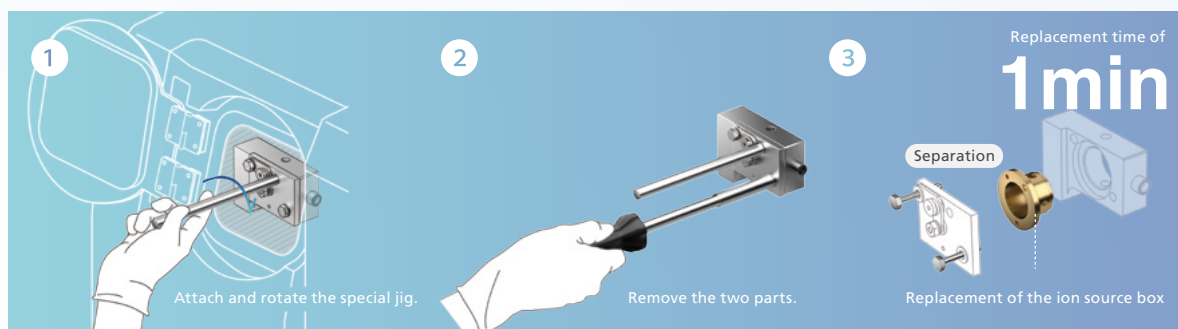

One-Touch GC Inlet Maintenance

The instrument is equipped as standard with a ClickTek™ nut, enabling the GC injection port to be attached or detached simply by manipulating a lever by hand, without tools.

Easy Startup and Shutdown from the Touch Panel

The vacuum system can be turned ON/OFF and Easy sTop* can be performed from the GC touch panel. Operations from a personal computer are not required, so maintenance of the GC injection port, column, and ion source can proceed with ease.

* This function guides the user through the replacement of the GC injection port septum and glass insert without turning OFF the vacuum system.

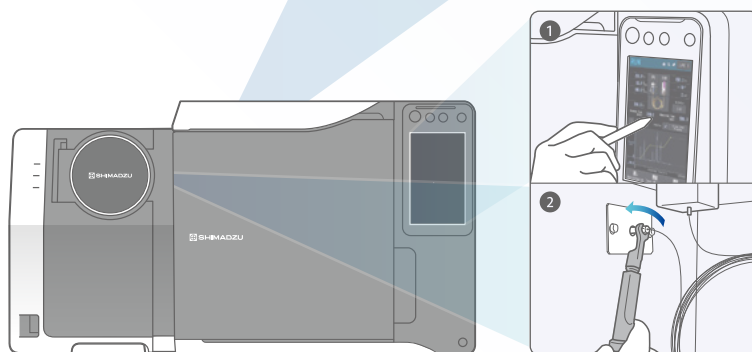



Anyone Can Achieve Analysis Results

Examination of the analytical conditions is indispensable for acquiring better data. The GCMS-QP2050 reduces the burden of examining these conditions, allowing even novice users to acquire data on par with an experienced operator.

Easily Analyze a Wide Range of Applications

With the completely new ion source and detector, the system is more than capable of detecting even trace compounds.



The new interface, which minimizes the production of cold spots, enables the acquisition of favorable peak shapes and sensitivity, even for compounds prone to adsorption.

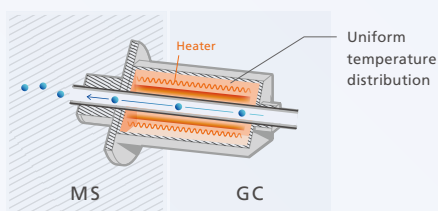

New Interface

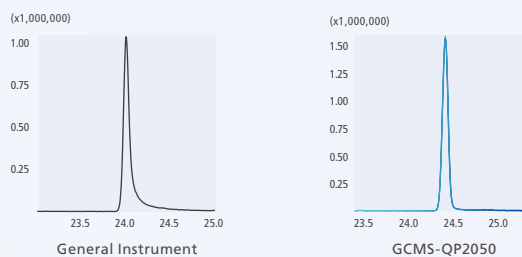

Example of the Analysis of Tetracontane (Straight-chain alkanes C₄₀H₈₂)

Ultra Fast Scanning Technology Supports Accurate Measurements

Advances to Shimadzu's impressive high-speed scan technology result in the industry's highest level of 30,000 u/sec. As a result, sensitivity on par with SIM analysis can be obtained even with FASST*¹. In addition, Advanced Scanning Speed Protocol (ASSP**²) minimizes sensitivity loss, even when the Scan measurement range is widened, enabling accurate qualitative analysis.

*¹ Fast Automated Scan/SIM Type: In this measurement mode, switching rapidly between Scan mode and SIM mode enables high-sensitivity SIM analysis and Scan analysis for component confirmation to be performed simultaneously in a single analysis.

**² By automatically optimizing the rod bias voltage during high-speed scans, this control technology minimizes sensitivity drops during high-speed scans.

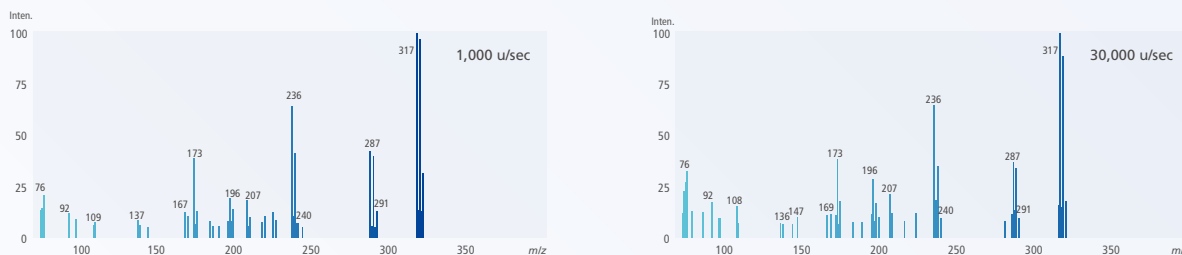

Mass spectra of Chlornitrofen

LabSolutions™ GCMS

Maximize Efficiency of the Entire Workflow

The efficiency of the analysis workflow is maximized by equipping the system and software with Analytical Intelligence, our latest user support technology.

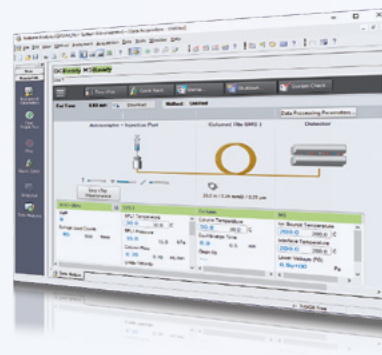

Preparation

Smart SIM+

Smart Database

Measurement

Active time management



Automatic Creation of Analysis Methods

Smart SIM™+ automatically creates the optimal analysis method. As a result, high-sensitivity and high-accuracy analysis is possible, even in multicomponent quantitative analysis.

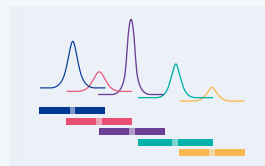

Database Optimized for Each Field

The compounds that need to be measured for each application are registered in Smart Database™. The optimized analytical conditions enable favorable measurement results to be obtained regardless of the operator's experience level.

AART | Automatic Adjustment of Retention Time

Simply by measuring an n-alkane solution, the system automatically adjusts the retention times for the target compounds.

Before column cutting

After column cutting

n-alkane

Target compounds

Automatic adjustments

Time Management of the Measurement Workflow



Instrument Name	Type	Analysis	Status	User	Queued Count	Estimated End Time
GC-2050	GC	All Operations	Not Connected	--	0	
GCMS-QP2050 (No1)	GCMS	All Operations	Not Connected	--	--	
GCMS-QP2050 (No2)	GCMS	Only Queuing	Running	User A	1	9/13/2023 2:00:00 PM

The operational status of each instrument in the laboratory and the finishing time of consecutive analyses can be assessed in real time. Additionally, the time remaining until completion of instrument startup and shutdown is displayed. This improves laboratory productivity and heightens efficiency.

Data Analysis

Peakintelligence

LabSolutions Insight™

Maintenance

Easy sTop

Active time management™

Automatic Peak Integration by Artificial Intelligence



Peakintelligence™ for GCMS, which is equipped with AI peak integration algorithms, significantly shortens the time required for peak integration and provides results comparable to those obtained by an experienced operator.

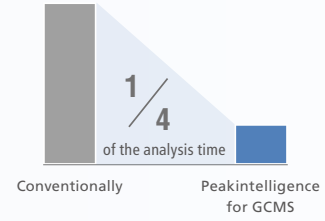

Improved Throughput for Multisample Data Analysis



The LabSolutions Insight multisample quantitative support software significantly reduces the time needed to analyze multisample data. Using flag, filter, and peak comparison functions, the multisample data can be narrowed down to the components that should be the focus.

Maintenance Navigation



The Easy sTop function enables safe maintenance of the sample injection port without stopping the vacuum. The standby time until maintenance can be performed is shown in real time.



- Automated support functions utilizing digital technologies, such as M2M, IoT, and Artificial Intelligence (AI), that enable higher productivity and maximum reliability.
- Allows a system to monitor and diagnose itself, handle any issues during data acquisition without user input, and automatically behave as if it were operated by an expert.
- Supports the acquisition of high quality, reproducible data regardless of an operator's skill level for both routine and demanding applications.

One Instrument, Infinite Possibilities

Conquering Helium Shortages

Minimizing the Usage of Helium Gas

Using the included carrier gas save function makes it possible to reduce the amount of carrier gas used during analysis. Additionally, with the optional gas selector, the carrier gas can be switched from helium to nitrogen except during analysis, thereby minimizing helium gas consumption during standby.

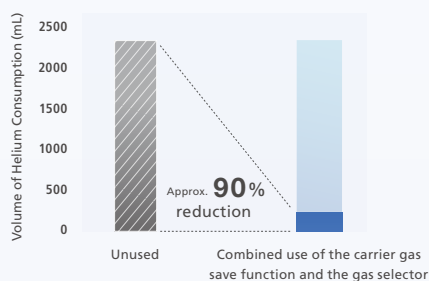
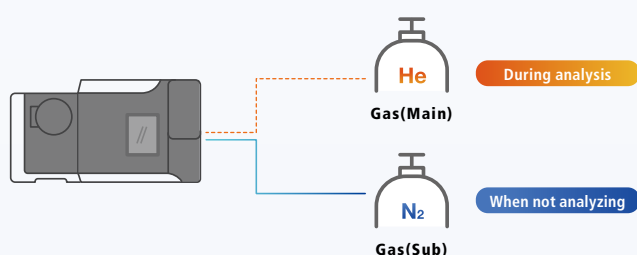

Reliable Operation with Alternative Carrier Gases

Hydrogen and nitrogen, which cost less and are easier to acquire, can be used as the carrier gas. With its high-performance flow controller and a design that reduces the impact of the carrier gas, the GCMS-QP2050 can perform stable measurements using either gas without modifying the instrument configuration.

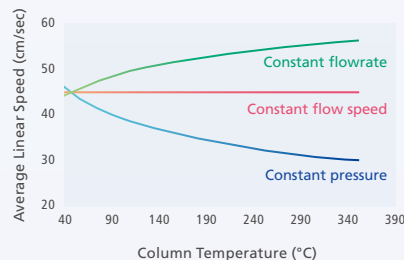
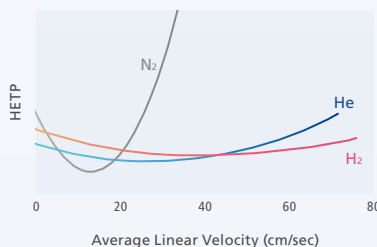
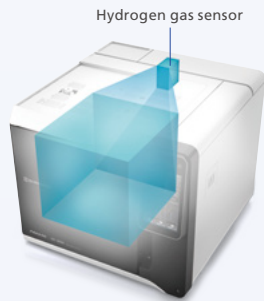

Hydrogen Carrier Gas

Hydrogen is the first choice as an alternative carrier gas from the perspective of sensitivity and separation. By installing the optional hydrogen sensor, if a leak occurs, the system automatically switches to safe standby mode, adding a level of comfort to anyone concerned about using hydrogen.

Nitrogen Carrier Gas

The GCMS-QP2050 demonstrates its true value when nitrogen is used as the carrier gas. In constant linear velocity mode, the system achieves separation on par with helium when using nitrogen, which has a narrow range of optimal linear velocities.

A Flexible Fit for Laboratories

Remote System Access

The system can be operated from a personal computer or tablet on the network via a LAN connection. Additionally, analysis and instrument status can be checked while away from the laboratory.



Compact Design Fits Anywhere

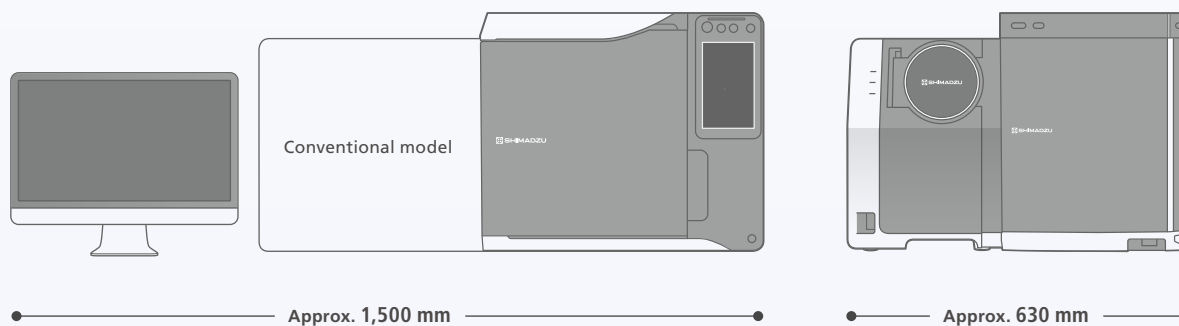

The GCMS-QP2050 saves on space. Thanks to remote access, there is no need to install a personal computer beside the instrument. This enables a flexible layout in the laboratory.

Twin Line MS System Simplifying the Column Exchange Process

Simultaneously attaching two different column outlets to the MS enables application data to be acquired from the different columns without breaking the MS vacuum. Since no resistance tube is utilized, the retention times used with a single column can be used as is.

*The Twin Line MS system requires optional parts.

*It must be used with suitable column sizes and analysis conditions.

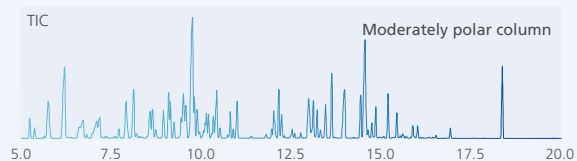
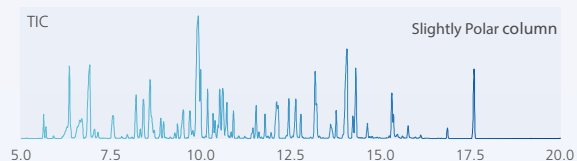

Analysis of fragrance components using Semi-polar and Moderately polar columns

"Smart Database" Series Supporting Wide Target Analysis

We offer GC-MS databases specialized in various fields. With the AART function, you can automatically correct retention times, allowing you to start analysis immediately.

Smart Pesticides Database™

It covers the pesticides (530 compounds) subject to GC-MS analysis and used inside and outside Japan. The database also contains information on compounds that can be used as internal standards. Therefore, it also supports analysis with the internal standard method.



Smart Metabolites Database™

The database contains 627 compounds including metabolites contained in food, blood, urine and cells. It also contains information on the stable isotopes of 38 major metabolites, which can be used as internal standards.



Smart Aroma Database™

We have registered 511 key aroma components. Our system supports a wide range of aroma analyses, from aroma profiling through scan analysis to high-sensitivity target analysis using SIM.

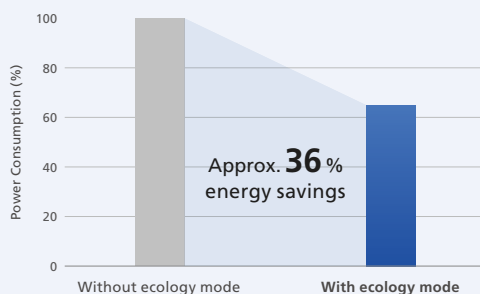

Energy Savings

The GCMS-QP2050 is equipped with ecology mode, which can reduce power consumption. It is also recognized as Eco-Products Plus, Shimadzu's proprietary recognition of environmentally friendly products. In addition to limiting analysis running costs, CO₂ emissions are limited, thereby contributing to a carbon-free society.

Best-in-Class Performance

HS-20 NX Headspace Sampler

The HS-20 NX headspace sampler provides powerful performance for the analysis of all types of volatile components related to both research and development and quality control. In addition, the electronic cooling trap enables high-sensitivity analysis of trace components.



TD-30 Thermal Desorption System

A thermal desorption system is an instrument that heats the sample tube, enriches the gas released, and then injects it into the GC-MS. The TD-30R provides excellent expandability, an extensive 120-sample processing capacity, a restore function, and a function that automatically adds the internal standard substance.



Pyrolysis Analysis System

High-polymer compounds undergo pyrolysis at temperatures of 500 °C or higher, and the thermal degradation products obtained are analyzed. These thermal degradation products reflect the structure of the original high-polymer compounds, enabling identification of the high polymers and better analysis of the higher order structure.



AOC™-6000 Plus Multifunctional Autosampler

This system can accommodate a variety of sample injection methods including liquid injection, headspace (HS) injection, and solid-phase micro extraction (SPME). It has an overlap function that heightens the efficiency of consecutive analyses. Further, with automatic syringe replacement and an agitation function, the system is capable of sample dilution, automatic addition of internal standard substances, and the automatic creation of calibration curve samples.



Tested & Proven Consumables

To obtain the correct analysis results requires high-quality consumables that minimize downtime. Shimadzu provides a wide ranging lineup of consumables that maximize GC and GC-MS system performance.

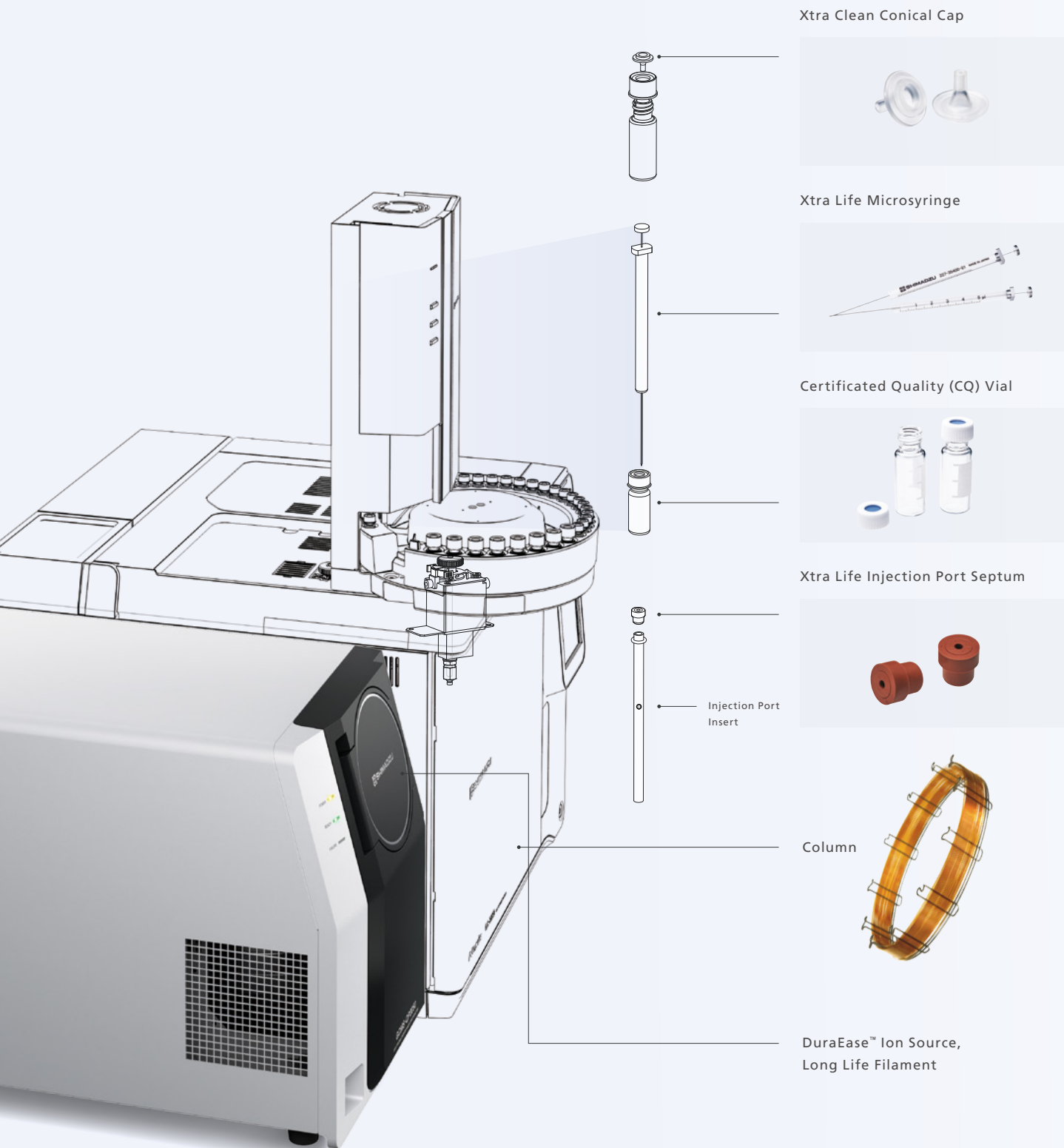

The image shows a Shimadzu GC-MS system with a vial carousel. To the right of the system, several consumables are listed with corresponding images and callouts pointing to their locations on the machine:

- Xtra Clean Conical Cap**: Two clear plastic caps, one with a central protrusion. Callout points to the top of a vial in the carousel.
- Xtra Life Microsyringe**: Two glass syringes with metal needles. Callout points to the injection port area.
- Certificated Quality (CQ) Vial**: Two glass vials, one with a blue cap. Callout points to a vial in the carousel.
- Xtra Life Injection Port Septum**: Two red, cylindrical septa. Callout points to the injection port.
- Injection Port Insert**: A small white cylindrical insert. Callout points to the injection port.
- Column**: A coiled metal filament. Callout points to the column compartment.
- DuraEase™ Ion Source, Long Life Filament**: A filament inside an ion source. Callout points to the ion source area.

Data Management

Network System: LabSolutions™ CS

With the network-compatible LabSolutions CS, data from a variety of analytical instruments can be unified for management in a database on the server computer. The data can then be loaded from any personal computer on the network. Additionally, the user and other system information is integrated with a server, heightening the efficiency of management work.

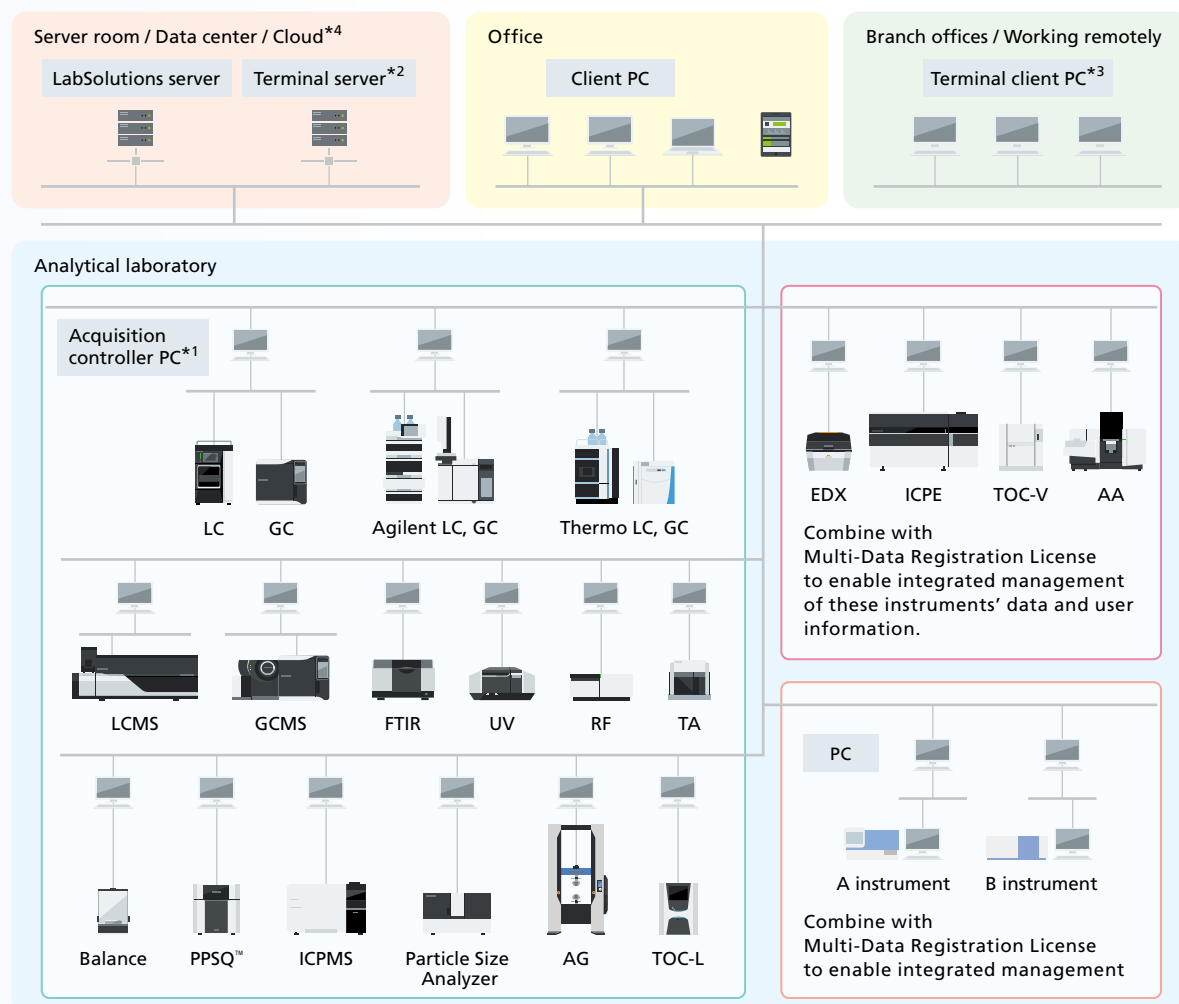

*1 The acquisition controller PC controls analytical instruments.

*2 A terminal server is a server for using terminal services. Users can view data reports and perform electronic signature operations through terminal services. It is ideal for remote connections because of the low network load. Only LC, GC, LCMS, and GCMS support analysis and post-run operations through terminal services.

*3 If a terminal service is used, LabSolutions software does not need to be installed on client PCs or tablets.

*4 Servers can be built on various clouds (IaaS). AWS (Amazon Web Services), Microsoft® Azure®, GCP™ (Google Cloud Platform™)

Stand-Alone System: LabSolutions™ DB

With the LabSolutions DB stand-alone system, the data is managed by connecting just a single PC to the analysis instrument, with no network connection. It is recommended when there are only a few instruments and users, and analysis is limited to a single PC for regulatory compliance.

ClickTek, ASSP, Smart SIM, Smart Database, Peakintelligence, LabSolutions, PPSQ, UFMS, LabSolutions Insight, Analytical Intelligence logo, DuraEase, Active Time Management and AOC are trademarks of Shimadzu Corporation or its affiliated companies in Japan and/or other countries.
Microsoft and Azure are either registered trademarks or trademarks of Microsoft Corporation in the United States and/or other countries.
Amazon Web Services and AWS are trademarks of Amazon.com, Inc. or its subsidiaries.
Google Cloud Platform and GCP are trademarks of Google LLC.



Shimadzu Corporation
www.shimadzu.com/an/

For Research Use Only. Not for use in diagnostic procedures.

This publication may contain references to products that are not available in your country. Please contact us to check the availability of these products in your country.

Company names, products/service names and logos used in this publication are trademarks and trade names of Shimadzu Corporation, its subsidiaries or its affiliates, whether or not they are used with trademark symbol "TM" or "®".

Third-party trademarks and trade names may be used in this publication to refer to either the entities or their products/services, whether or not they are used with trademark symbol "TM" or "®".

Shimadzu disclaims any proprietary interest in trademarks and trade names other than its own.

The contents of this publication are provided to you "as is" without warranty of any kind, and are subject to change without notice. Shimadzu does not assume any responsibility or liability for any damage, whether direct or indirect, relating to the use of this publication.